



2310 E. Orangethorpe Ave, Anaheim, CA 92806

714-738-6194 / 714-446-0119 FAX

www.accrmfg.com

Series 3370 - Product Specification

Part Number Code:

	3370	MVW	BA	- X.XX	H	L	R	
ACCR Series								Option R = Locknut for retaining the screw
Hardware Option:								Option L = Locking Element on screw threads
1st Position Blank = 9/64" Hex Socket Std								
M = Metric 3mm Hex Socket Head on Screw (9/64" Hex Socket Std)								
V = Visual Lock indicator (add .20" to screw length)								
W = Lock and Flat Washer (add .100" to screw length)								
Finish Option:								Mounting Options:
BA = Black Anodize per Mil-A-8625, Type II, Class 2								E = Extra mounting hole
BH = Black Hard Anodize per Mil-A-8625, Type III, Class 2								H = C'bore .156" Dia. X .200" Deep X .068/.073" Dia.
CC = Chem-Film Clear per Mil-C-5541 (ROHS)								Hole Thru, CSK 100 degree X .140" Dia.
CG = Chem-Film Gold per Mil-C-5541								T0 = 0-80 Tapped Thru Holes
EN = Electroless Nickel per Mil-C-26074								T2 = 2-56 Tapped Thru Holes
BL = Black Hard Anodize with Dry Film Lube per Mil-L46010								TM2 = Metric 2 Tapped Thru Holes
RA = Red Anodize per Mil-A-8625, Type II, Class 2								TM2.5 = Metric 2.5 Tapped Thru Holes
								P = Indexing Pins .062 x .050" (two positions only)
								Assembly Length in decimal inches:
								Standard lengths = 2.80, 3.80 and 4.80
								Other lengths or specifications on request.

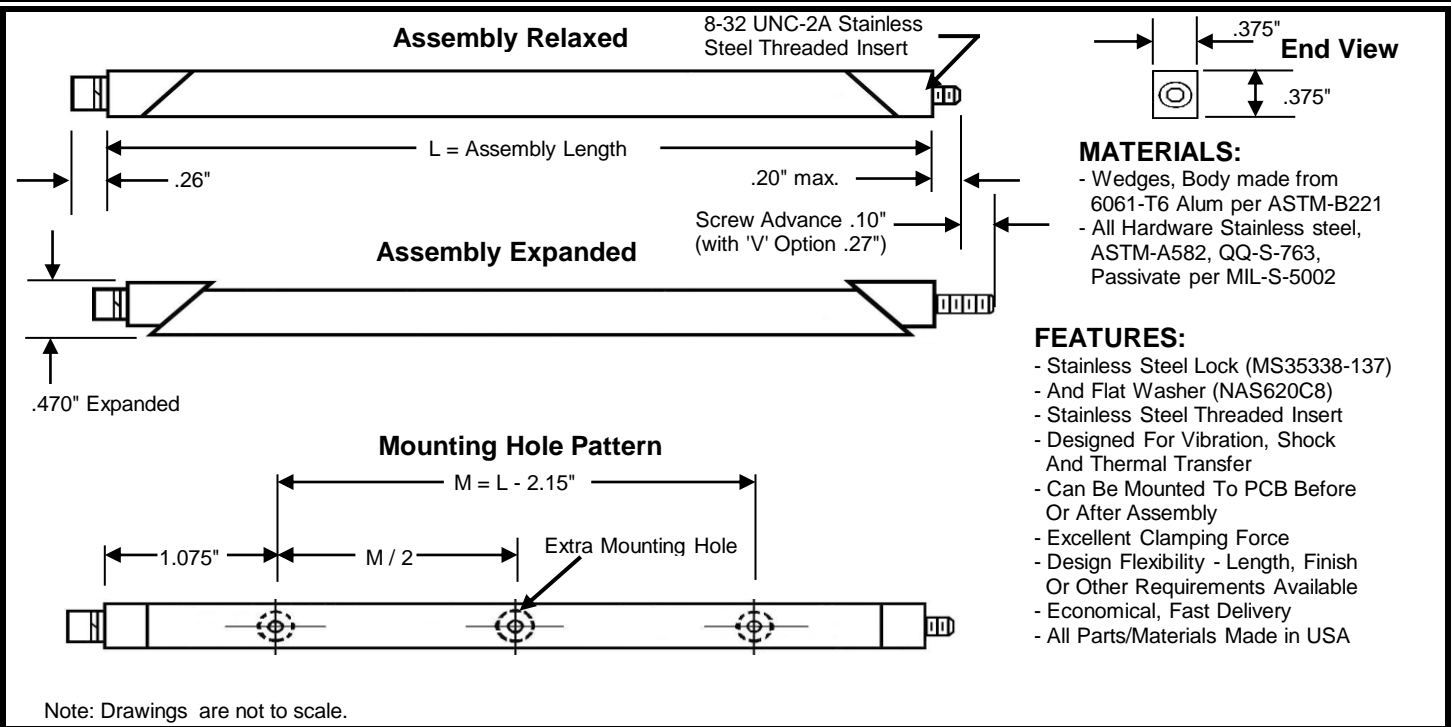

Note: Drawings are not to scale.

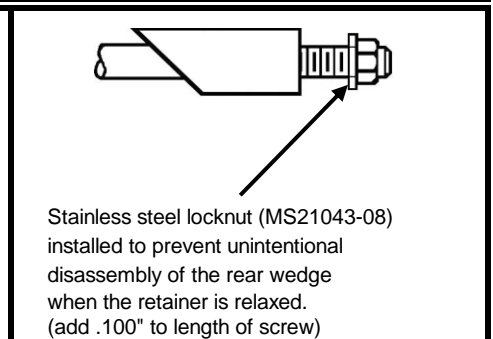
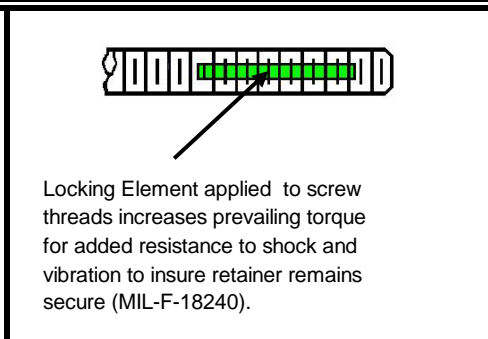
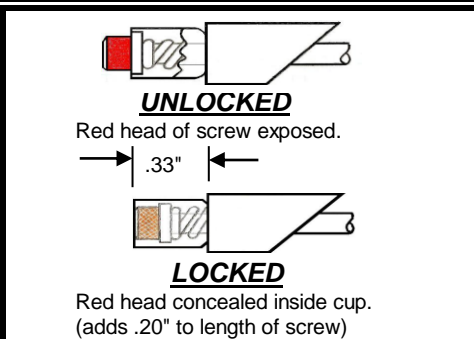

"V" Option:
Provides color code on the screw head as a visual indicator the retainer is locked.

"L" Option:
Adds Lock Patch to screw threads for additional resistance to shock and vibration.

"R" Option:
Add MS21043 Lock Nut to prevent unintentional disassembly of rear wedge.