



2310 E. Orangethorpe Ave, Anaheim, CA 92806
 714-738-6194 / 714-446-0119 FAX
 www.accrmfg.com

Series 1750-X Extractor Lever Product Specification

Part Number Code:

1750-X **PP** **BA** **SS**

Injector / Ejector Series and Card Size

X = Card thickness in 32nds

1 = 1/32" Card Thickness (.031" REF)
 2 = 2/32" Card Thickness (.062" REF)
 3 = 3/32" Card Thickness (.093" REF)
 4 = 4/32" Card Thickness (.125" REF)

Hardware Option:

PP = Pre-Started Assembly Pin
 Blank = One Loose Pin (Stainless 3/32" X 1/4") per Lever

SilkScreen Option:

SS = SilkScreen Required (per customer request/artwork)
 Leave Blank = None Required

Finish Option:

BA = Black Anodize per Mil-A-8625, Type II, Class 2
 BH = Black Hard Anodize per Mil-A-8625, Type III, Class 2
 CC = Chem-Film Clear per MIL-C-5541, CL 3 (ROHS)
 CG = Chem-Film Gold per MIL-C-5541, CL 1A
 RA = Red Anodize per Mil-A-8625, Type II, Class 2
 Other colors available on request.

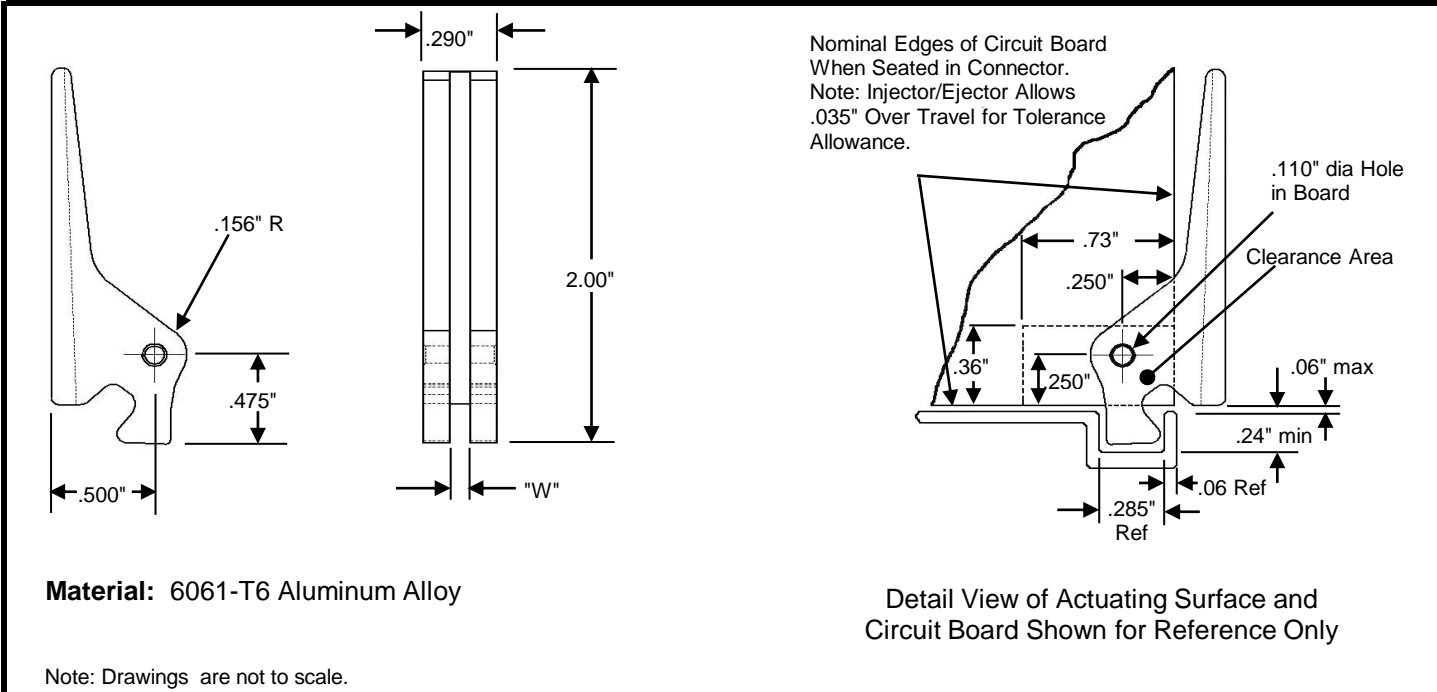

BOARD THICKNESS CHART:

Part #	Board Thickness	"W" Dim
1750-1	1/32 - .031	.048"
1750-2	2/32 - .062	.080"
1750-3	3/32 - .093	.110"
1750-4	4/32 - .125	.140"

****ACCR Products are 100% Made in the USA.**

- FEATURES:**
- *High-Strength Lever Action Design Overcomes Extreme Insertion and Ejection Forces.
 - *Actuates from a Simple "U" Channel Form.
 - *Available with Conductive Finish.
 - *Clearance Chamfer not Required on Circuit Board.
 - *Narrow Profile to Minimize Interference.

APPLICATION DATA:

Two Inserter-Extractors are Recommended per Board. Provides Insertion and Ejection Travel of .35" Minimum with a Mechanical Advantage of Approximately 4.5 : 1.